

8 7 6 5 4 3 2 1

D
C
B
A

D
C
B
A

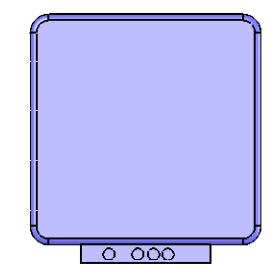
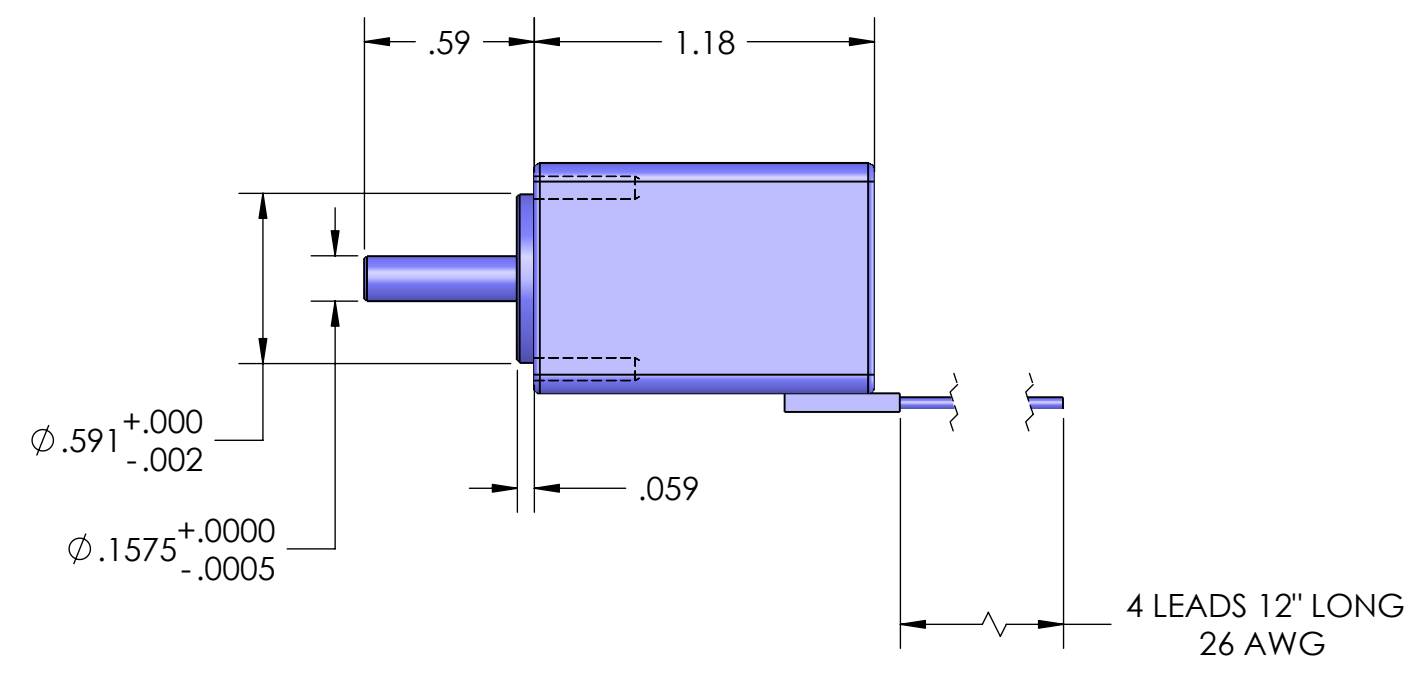
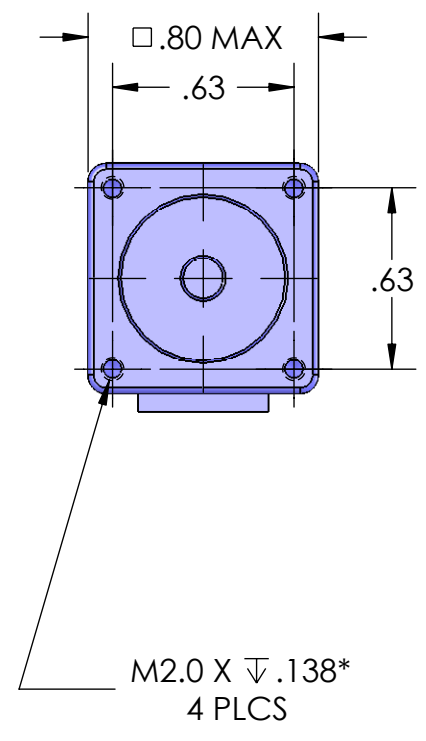

PROPRIETARY AND CONFIDENTIAL
THE INFORMATION CONTAINED IN THIS DRAWING IS THE SOLE PROPERTY OF USAUTOMATION ANY REPRODUCTION IN PART OR AS A WHOLE WITHOUT THE WRITTEN PERMISSION OF USAUTOMATION IS PROHIBITED.

		UNLESS OTHERWISE SPECIFIED:		NAME	DATE
		DIMENSIONS ARE IN INCHES TOLERANCES: FRACTIONAL $\pm 1/32$ ANGULAR: MACH $\pm .5^\circ$ BEND $\pm 1^\circ$ TWO PLACE DECIMAL $\pm .03$ THREE PLACE DECIMAL $\pm .005$		DRAWN	
		INTERPRET GEOMETRIC TOLERANCING PER:		CHECKED	
		MATERIAL		ENG APPR.	
NEXT ASSY	USED ON	FINISH		MFG APPR.	
APPLICATION		DO NOT SCALE DRAWING		Q.A.	
				COMMENTS:	
 23011 MOULTON PARKWAY, SUITE J2 LAGUNA HILLS, CA 92653 949-588-0581					
TITLE: USS08T21XX-4S					
SIZE	DWG. NO.			REV	
B					
SCALE: 3:2		WEIGHT:		SHEET 1 OF 1	

8 7 6 5 4 3 2 1