

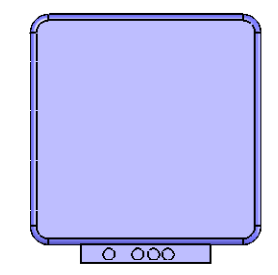

8 7 6 5 4 3 2 1

D
C
B
A

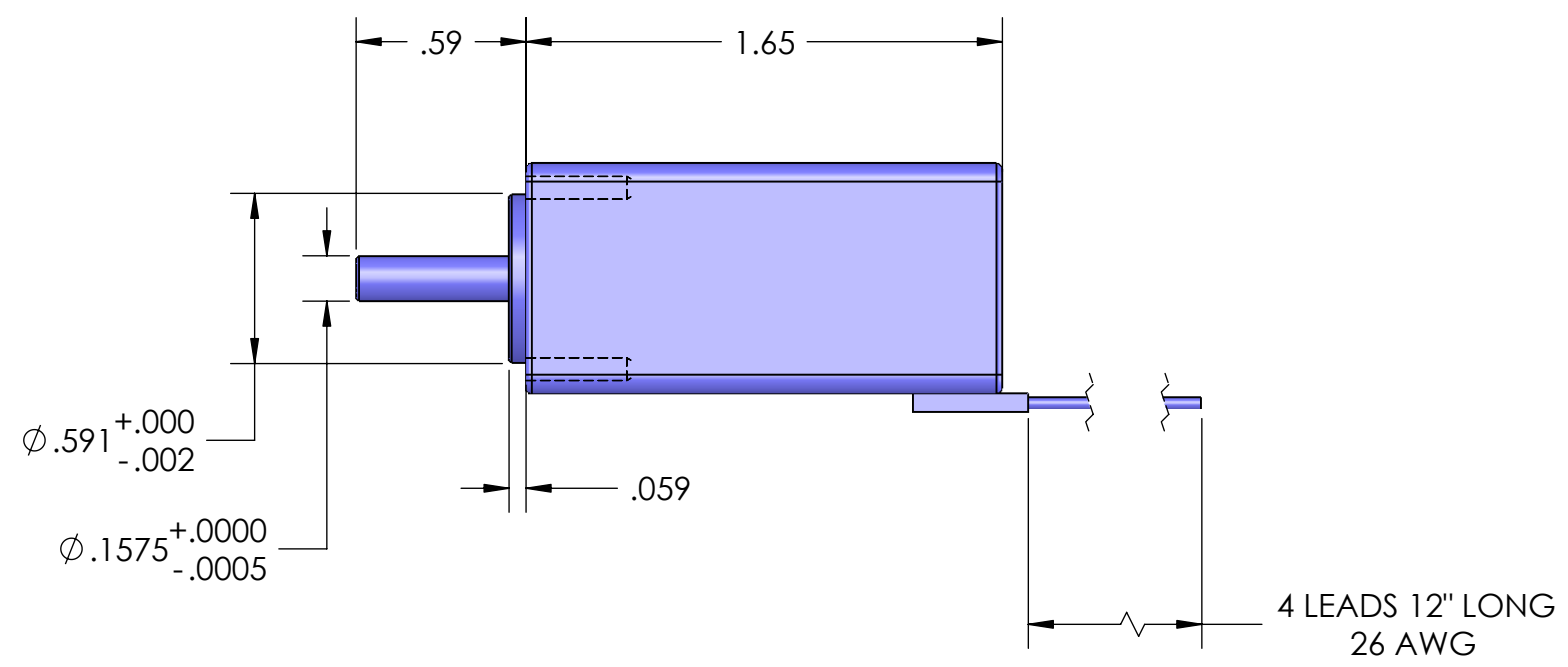
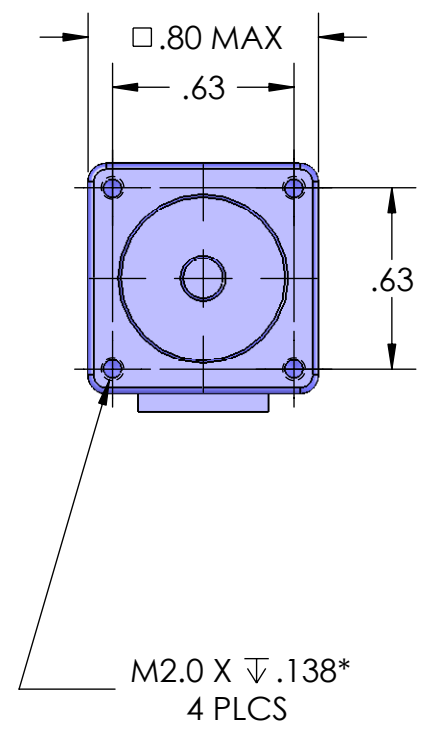

PROPRIETARY AND CONFIDENTIAL
THE INFORMATION CONTAINED IN THIS DRAWING IS THE SOLE PROPERTY OF USAUTOMATION ANY REPRODUCTION IN PART OR AS A WHOLE WITHOUT THE WRITTEN PERMISSION OF USAUTOMATION IS PROHIBITED.

		UNLESS OTHERWISE SPECIFIED:		NAME	DATE
		DIMENSIONS ARE IN INCHES		DRAWN	
		TOLERANCES:		CHECKED	
		FRACTIONAL $\pm 1/32$		ENG APPR.	
		ANGULAR: MACH $\pm .5^\circ$ BEND $\pm 1^\circ$		MFG APPR.	
		TWO PLACE DECIMAL $\pm .03$		Q.A.	
		THREE PLACE DECIMAL $\pm .005$		COMMENTS:	
		INTERPRET GEOMETRIC TOLERANCING PER:			
		MATERIAL			
NEXT ASSY	USED ON	FINISH			
APPLICATION		DO NOT SCALE DRAWING			



23011 MOULTON PARKWAY, SUITE J2
LAGUNA HILLS, CA 92653
949-588-0581

TITLE: **USS08T23XX-4S**

SIZE B	DWG. NO.	REV
---------------	----------	-----

SCALE: 3:2 WEIGHT: SHEET 1 OF 1

8 7 6 5 4 3 2 1