

8 7 6 5 4 3 2 1

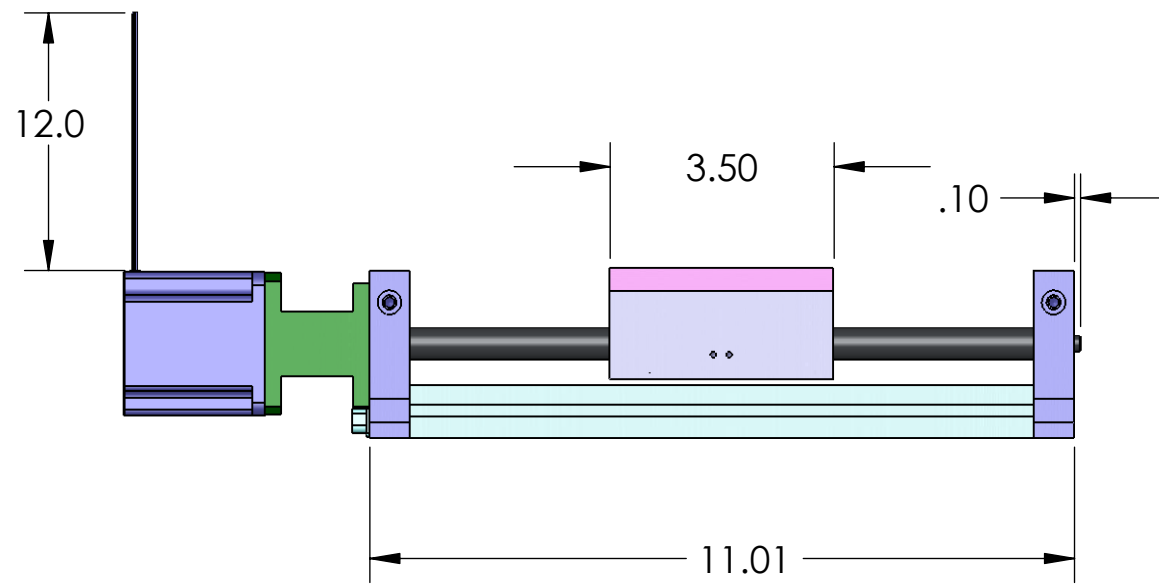
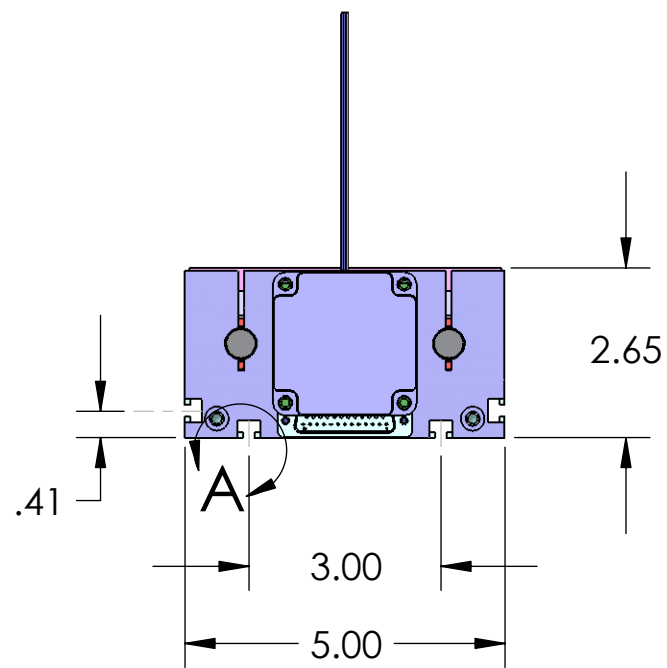
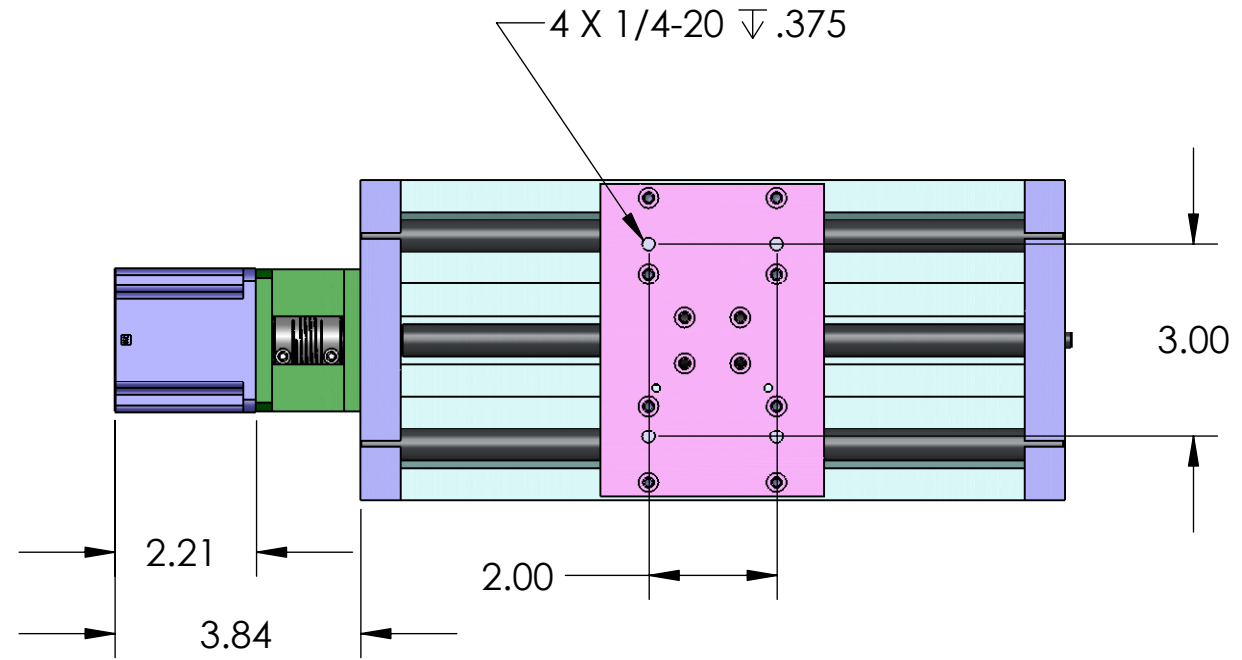
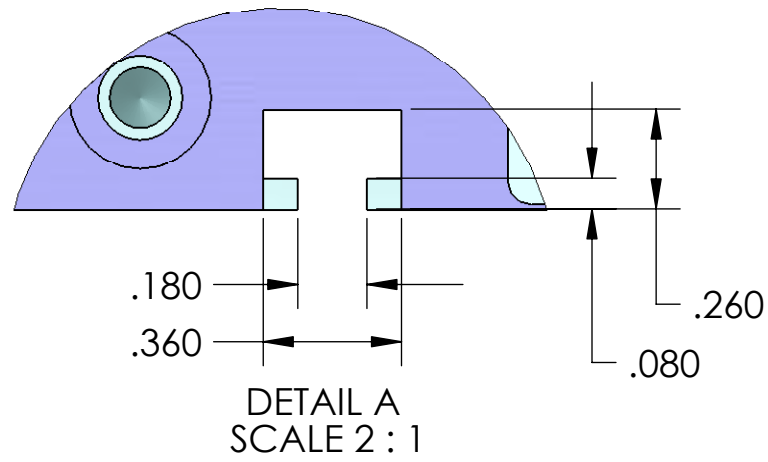

PROPRIETARY AND CONFIDENTIAL
THE INFORMATION CONTAINED IN THIS DRAWING IS THE SOLE PROPERTY OF USAUTOMATION ANY REPRODUCTION IN PART OR AS A WHOLE WITHOUT THE WRITTEN PERMISSION OF USAUTOMATION IS PROHIBITED.

		UNLESS OTHERWISE SPECIFIED:		NAME	DATE
		DIMENSIONS ARE IN INCHES		DRAWN	
		TOLERANCES:		CHECKED	
		FRACTIONAL ± 1/32		ENG APPR.	
		ANGULAR: MACH ± .5° BEND ± 1°		MFG APPR.	
		TWO PLACE DECIMAL ± .03		Q.A.	
		THREE PLACE DECIMAL ± .005		COMMENTS:	
		INTERPRET GEOMETRIC TOLERANCING PER:		BREAK ALL EDGES 0.025 MAX	
		MATERIAL			
		FINISH			
NEXT ASSY	USED ON				
APPLICATION		DO NOT SCALE DRAWING			
				 23011 MOULTON PARKWAY, SUITE J2 LAGUNA HILLS, CA 92653 949-588-0581	
				TITLE: UST80XXZ-06-S-0	
		SIZE B	DWG. NO.	REV	
		SCALE: 1:3	WEIGHT:	SHEET 1 OF 1	

8 7 6 5 4 3 2 1